



# THE VALLEY RUN 2018

## SUPPLEMENTARY REGULATIONS 2 / 4 WHEELERS - OPEN

**13 to 15 APRIL, 2018**

**Venue:  
Aamby Valley City Air Strip  
Ambavane, Pune**

Promoted & Organised by



in Association with  
(Sporting Aspects only)



Approved by



Name of the event	THE VALLEY RUN 2018
Start Date of the event	13 APRIL 2018
End Date of the event	15 APRIL 2018
Status of the event	OPEN
Category	2W and 4W
Name of the Organizer	ELITE OCTANE INC.
Address	
Phone	
Email	info@eliteoctane.com
Website	www.eliteoctane.com
<b>In Association with (if any)</b>	
Name of the Organizer	SPORTSCRAFT (Sporting Aspects only)
Address	Chitrakut 3rd Floor, Siri Road, Chowpatty Bandstand, Malabar Hill, Mumbai 400006
Phone	+91-22-23677631
Email	sportscraft.drag@gmail.com
Website	sportscraftindia.com

Approved by



## WARNING

**MOTORSPORT CAN BE DANGEROUS. DESPITE ORGANIZERS TAKING ALL POSSIBLE PRECAUTIONS UNAVOIDABLE ACCIDENTS MAY HAPPEN. YOU ARE PRESENT HERE AT YOUR OWN RISK.**

## **TABLE OF CONTENTS**

<b>1. INTRODUCTION</b>	<b>4</b>
<b>2. ORGANIZATION</b>	<b>4</b>
<b>3. PROGRAMME</b>	<b>5</b>
<b>4. ENTRIES</b>	<b>6</b>
<b>5. INSURANCE</b>	<b>9</b>
<b>6. ADVERTISEMENT AND IDENTIFICATION</b>	<b>9</b>
<b>7. ADMINISTRATIVE CHECKS</b>	<b>10</b>
<b>8. PRE-EVENT SCRUTINEERING, SEALING AND MARKING</b>	<b>10</b>
<b>9. IDENTIFICATION OF OFFICIALS</b>	<b>10</b>
<b>11. PRIZES</b>	<b>11</b>
<b>12. PROTEST &amp; APPEAL</b>	<b>12</b>
<b>13. RUNNING OF THE EVENT</b>	<b>13</b>
<b>14. SAFETY REQUIREMENTS</b>	<b>14</b>
<b>NAMES AND PHOTOGRAPHS OF CRO'S</b>	<b>14</b>

## 1. Introduction

- 1.1 THE VALLEY RUN 2018 is run in compliance with the 2018 International Sporting Code of the Federation Internationale de l'Automobile (FIA), 2018 FMSCI General Prescriptions for Drag Racing, the relevant Drag Technical Regulations and these Supplementary Regulations (SRs).

The Federation of Motor Sports Clubs of India (FMSCI) is the National Sporting Authority (ASN) of FIA in India.

Modifications, amendments and / or changes to these SRs will be announced only by numbered and dated bulletins, issued by the organizers, approved by the FMSCI or Stewards.

- 1.2 Acquaintance with and submission to Rules

Every person, or group of persons, organizing a competition or taking part therein

- Shall be deemed to be acquainted with all the relevant rules and regulations of the FMSCI
- All competitors must sign the indemnity and declaration form, which are enclosed with the Entry Form
- These are conditions precedent attached to the submission of entries and taking part in an event and all competitors participating shall be bound by them and also the rules and regulations hereinafter set out or amendments made thereto.
- Shall undertake to submit themselves without reserve to the above and to the decision and consequences resulting therefrom.

## 2. Organization

- 2.1 **FMSCI Permit No./s :**

- 2.2 **Organizers name, address and contact details**

ELITE OCTANE INC.  
info@eliteoctane.com  
www.eliteoctane.com

- 2.3 **Managing Committee**

- 2.4 **Organizing Committee**

Rongom Tagore Mukerji	Shrikant Karani	Bhavin Jagda
Stuart Lima	Antony Nadar	Utpal Tijoriwala
ShekharDhuri	Manish Chitko	Shamim Khan
PriyankaTulaskar	Suraj Kute	Anish Nair
Ashok Shenvi	Hersh Shivdasani	Kaustubh Machhe

## 2.5 FMSCI Officials

Chief Steward	V. Shyam Kumar
Steward	Roopesh Thakkar
Club Steward	Manish Chitko
Chief Scrutineer	Ravindra Waghchoure

## 2.6 Senior Officials

Clerk of the Course	Shrikant Karani
Assistant Clerk of the Course	Rongom Tagore Mukerji
Secretary of the Meet	Utpal Tijoriwala
Chief Safety Officer	
Chief Medical Officer	TBA
Chief Time Keeper	Jonathan Richardson
Competitors Relations Officer	Rongom Mukerji
Media Relations Officer	
Results Co-ordinator	Utpal Tijoriwala

## 2.7 Location of HQ

### From:

Day	DD / MM / YYYY	Time (hrs)	Venue
MONDAY	26-MAR-2018	10:00 hrs	Sportscraft Office

### To:

THURSDAY	12-APR-2018	16:30 hrs	Sportscraft Office
----------	-------------	-----------	--------------------

### From:

Day	DD / MM / YYYY	Time (hrs)	Venue
FRIDAY	13-APR-2018	09:00 hrs	Aamby Valley Air Strip

### To:

SUNDAY	15-APR-2018	18:00 hrs	Aamby Valley Air Strip
--------	-------------	-----------	------------------------

## 2.8 Secretariat Address

**Main Office for all Correspondence and Courier: From 27 March 2018 to 07 April 2018**

### **SPORTSCRAFT**

Chitrakut 3rd Floor, Siri Road, Chowpatty Bandstand,

Malabar Hill, Mumbai 400006

Tel: +91-22-23677631

**Alternate From 26 March 2018 to 5 April 2018**

### **N1 Racing Equipment**

2E, Block no. 7, Sun Mill Compound, Opp. Maruti Temple,

Lower Parel (west), Mumbai, Maharashtra 400013

Tel: +91-22-24947421

### 3. Programme

Time	Details
Publication of SR	Entries open with publication of these Regulations
07 April 2018 till 15:00 hrs	Closing of Standard Entries
09 April 2018 till 16:00 hrs	Closing of Late Entries (with additional Fees)
10 April 2018 - 15:00 hrs	Document Verification
11 April 2018 - 17:00 hrs	Publication of Entry List on EOI website and Event page on FB

<b>FRIDAY, 13 APRIL 2018 (at Event Venue)</b>	
Time	Details
13 April 2018 09:00 to 12:00 hrs. (after which late fees applicable upto 14:00 hrs)	Documentation Check + Pre Event Scrutiny (M1, M2, M3, M4)
13 April 2018 13:00 to 16:30 hrs. (after which late fees applicable upto 17:30 hrs)	Documentation Check + Pre Event Scrutiny (M5, M6, O1, W1, A1, A2, A3, A4, B1 to B7, G1, K1 to K7)
13 April 2018 14:15 hrs.	Briefing Meeting
13 April 2018 14:30 hrs.	Start of Drag (M1, M2, M3, M4)
Approx. at 18:30 hrs	Prize Distribution for Races run during the day

<b>SATURDAY, 14 APRIL 2018 (at Event Venue)</b>	
Time	Details
14 April 2018 08:30 hrs.	Briefing Meeting
14 April 2018 09:15 hrs.	Start of Drag (M5, M6, O1, A1, A2, A3, A4, B1, B2, B3, B4, B5, B6, B7, G1, K1 to K7, W1)
14 April 2018 10:00 to 13:00 hrs. (after which late fees applicable upto 16:00 hrs)	Documentation Check + Pre Event Scrutiny (M7, M8, M9, M10, P, O2, W2, A5, A6, A7, F, G2, H1, H2, H3, I1, I2, I3, J)
Approx. at 18:30 hrs	Prize Distribution for Races run during the day

<b>SUNDAY, 15 APRIL 2018 (at Event Venue)</b>	
Time	Details
15 April 2018 08:30 hrs.	Briefing Meeting
15 April 2018 09:15 hrs.	Start of Drag (M7, M8, M9, M10, P, O2, W2, A5, A6, A7, F, G2, H1, H2, H3, I1, I2, I3, J)
Approx. at 18:30 hrs	Prize Distribution for Races run during the day

**NOTE:**

If any vehicle does not complete documentation and/or scrutiny in above stipulated time, the entry will be forfeited and the vehicle will not be allowed to start.

## 4. Entries

### 4.1 Opening and Closing Dates

Entries open with the publication of these Supplementary Regulations

Starting date of Entries: 26 MARCH 2018 @ 10:30 hrs

Closing date of Standard entries: 07 APRIL 2018 @ 15:00 hrs

Closing date of Late entries: 09 APRIL 2018 @ 16:00 hrs

(Additional fees INR 2000 + 18% GST applicable for late entries)

### 4.2 Entry Procedure

Those wishing to take part in the event must send the enclosed entry form duly completed to the permanent secretariat address given in Art.2.8 prior to the closing date as mentioned in Art.4.1

### 4.3 Maximum number of Entries

The maximum number of entries accepted would be no more than 600. If more entries are than these are received, then the organizers reserve the right to decide which entries would be accepted or accept on the basis of available time schedule.

### 4.4 Category, Groups & Classes & Entry Fees – OPEN Categories

<input type="checkbox"/> 2 Wheelers - 2 Stroke - Super Sport Indian	
Class M	Entry Fees (INR)
<input type="checkbox"/> Upto 165 cc (M1)	3,540.00
<input type="checkbox"/> 166 to 375 cc (M2)	3,540.00

<input type="checkbox"/> 2 Wheelers - 4 Stroke - Super Sport Indian	
Class M	Entry Fees (INR)
<input type="checkbox"/> Upto 165 cc (M3)	3,540.00
<input type="checkbox"/> 166 cc – 225 cc (M4)	3,540.00
<input type="checkbox"/> 226 cc – 360 cc (M5)	3,540.00
<input type="checkbox"/> 361 cc – 550 cc (M6)	3,540.00
<input type="checkbox"/> Indian Open (O1)	5,900.00
<input type="checkbox"/> Indian Wheelie (W1)	3,540.00

<input type="checkbox"/> 2 Wheelers - 4 Stroke - Super Sport	
Class M	Entry Fees (INR)
<input type="checkbox"/> 551 cc – 850 cc (Sport - Inline 3/4) (M7)	5,900.00
<input type="checkbox"/> 649 cc – 850 cc (Single / Twin) (M8)	5,900.00
<input type="checkbox"/> 851 cc – 1050 cc (M9)	5,900.00
<input type="checkbox"/> 1051 cc and above (M10)	5,900.00
<input type="checkbox"/> Muscle (P)	5,900.00
<input type="checkbox"/> Foreign Open (O2)	8,260.00

<input type="checkbox"/> Foreign Wheelie ( <b>W2</b> )	5,900.00
--	----------

<input type="checkbox"/> <b>4 Wheelers - Pro Stock Petrol</b>	
<b>Class B</b>	<b>Entry Fees (INR)</b>
<input type="checkbox"/> Upto 1150 cc ( <b>B1</b> )	5,900.00
<input type="checkbox"/> 1151 cc – 1450 cc ( <b>B2</b> )	5,900.00
<input type="checkbox"/> 1451 cc – 1650 cc ( <b>B3</b> )	5,900.00
<input type="checkbox"/> 1651 cc – 2050 cc ( <b>B4</b> )	5,900.00
<input type="checkbox"/> 2051 cc – 2550 cc ( <b>B5</b> )	5,900.00
<input type="checkbox"/> 2551 cc – 3060 cc ( <b>B6</b> )	5,900.00
<input type="checkbox"/> 3061 cc and above ( <b>B7</b> )	5,900.00

<input type="checkbox"/> <b>4 Wheelers - Pro Stock Diesel</b>	
<b>Class K</b>	<b>Entry Fees (INR)</b>
<input type="checkbox"/> Upto 1150 cc ( <b>K1</b> )	5,900.00
<input type="checkbox"/> 1151 cc – 1450 cc ( <b>K2</b> )	5,900.00
<input type="checkbox"/> 1451 cc – 1650 cc ( <b>K3</b> )	5,900.00
<input type="checkbox"/> 1651 cc – 2050 cc ( <b>K4</b> )	5,900.00
<input type="checkbox"/> 2051 cc – 2550 cc ( <b>K5</b> )	5,900.00
<input type="checkbox"/> 2551 cc – 3060 cc ( <b>K6</b> )	5,900.00
<input type="checkbox"/> 3061 cc and above ( <b>K7</b> )	5,900.00

<input type="checkbox"/> <b>4 Wheelers – Indian Cars with Foreign Engine</b> (minimum 4 to form Class or the class will be merged with the next higher Class). Cannot run in Indian Open, but can take part in Unrestricted Class	
<b>Class F</b>	<b>Entry Fees (INR)</b>
<input type="checkbox"/> (F)	8,260.00

<input type="checkbox"/> <b>4 Wheelers– Indian Open (Stock &amp; Unrestricted)</b>	
<b>Class G</b>	<b>Entry Fees (INR)</b>
<input type="checkbox"/> Indian Open ( <b>G1</b> ) – Stock Body	5,900.00
<input type="checkbox"/> Indian Open ( <b>G2</b> ) – Altered / Unrestricted	5,900.00

<input type="checkbox"/> <b>4 Wheelers – PRO STOCK – Petrol/Diesel - Foreign</b>	
<b>Class I</b>	<b>Entry Fees (INR)</b>
<input type="checkbox"/> Upto 3000 cc ( <b>I1</b> )	8,260.00
<input type="checkbox"/> 3001 to 4000 cc ( <b>I2</b> )	8,260.00
<input type="checkbox"/> 4001 cc and above ( <b>I3</b> )	8,260.00

<input type="checkbox"/> <b>4 Wheelers – Unrestricted – Indian, Foreign (All types)</b>	
<b>Class J</b>	<b>Entry Fees (INR)</b>
<input type="checkbox"/> All types (J)	8,260.00



<input type="checkbox"/> <b>4 Wheelers – Exhibition – Indian, Foreign (All types)</b>	
<b>Class E (invitation Only)</b>	<b>Entry Fees (INR)</b>
<input type="checkbox"/> All types (E)	4,130.00

Entry fees are inclusive of taxes applicable (i.e. 18% GST).

#### 4.5 **Payment**

The entry fees can be either by demand draft in favour of ELITE OCTANE MOTORING PVT. LTD. payable at MUMBAI or by cash.

#### 4.6 **Refund**

Entries fees will be refunded in full only:

- To candidates whose entry has not been accepted
- In case of event not taking place

The organizers may refund 50% of the entry fee to those competitors who, for reasons of force-majeure (duly accepted by the organizing committee) were unable to start in the event.

## 5. Insurance

Organizers holding a valid 2018 FMSCI Permit for an event are covered for

**Competitors** : A maximum of 250 competitors with valid FMSCI Competition License participating in various events across the Country on a given day are covered for Personal Accident Insurance for Rs. 5 lakhs with Rs. 5 Lakhs medical expense extension per person.

**Officials** : A maximum of 100 officials officiating in various events across the Country on a given day are covered for Personal Accident Insurance for Rs.25 lakhs with Rs.1 lakh medical expense extension per person.

THESE INSURANCES ARE ISSUED BY NEW INDIA INSURANCE COMPANY LTD AND VALID DURING THE RUNNING OF THE EVENT ONLY. ORGANIZERS / COMPETITORS ARE ADVISED TO TAKE ANY ADDITIONAL INSURANCES THEY MAY DEEM FIT. IF THEY HAVE MORE THAN 100 OFFICIALS & ALSO REQUIRE DOOR TO DOOR COVERAGE PLEASE CONTACT: S.MANIKANDAN@STENHOUSE.IN

Third Party Liability Insurance (Minimum 50 lakhs) taken by the Organizers

Dates covered: 13 to 15 APRIL 2018

Amount:

Company:

## 6. Advertisement and Identification

6.1 It is compulsory to carry organizers advertisement on the competing vehicles.

6.2 Competitors are allowed to affix any kind of advertisements on their vehicle provided that

- Any instructions issued by the organisers are observed.
- It is authorized by the National laws and FMSCI regulations
- Advertising must not be of a political, obscene or insulting nature. It must be in good taste and not conflict with the vehicles official numbers in any way
- It should not be placed as to prevent recognition by Officials or Marshals.
- The space designated in Appendix '4' of the General Prescription is left free of advertising other than that provided by the organisers.
- It does not encroach upon the spaces reserved for rally plates, number plates and windscreen strips,
- It does not interfere with the driver's vision through the windows.

## 7. Administrative checks

### 7.1 Documents Submission

Entrants should produce the following for inspection at the time of submitting the vehicle for pre-event scrutiny and administrative check on the date / time as mentioned in Art.3.

Competitors are required to bring:

- Special DragInsurance cover valid for the dates of the event (Recommended)
- Authority letter from owner of the vehicle if the driver / rider is not the owner of the vehicle used in the event
- FMSCI Competition License for Driver (Minimum 4W Clubsport DragLicence. Apply online at <http://licence.fmsci.co.in/>)
- Entrant Licence / FMSCI Registration (if any)
- Pan Card copy of Competitor
- 3 Passport size photographs

Competitors are required to carry all the above documents throughout the event. All the documents shall be valid for the date(s) of the event.

## 8. Pre-event Scrutineering, Sealing and Marking

### 8.1 Venue & Timings

Place: Aamby Valley Air Strip

Date: 13 APRIL 2018

Time: 11am onwards

## 9. Identification of Officials

Safety Marshal	Orange
Safety Officer	Orange with white stripe and text
Post Chief	Blue with white stripe and text
Media	Green
Stage Commander	Red with text
Competitor Relations Officer	Red Jacket or Red Tabard
Medical	White
Radio	Yellow with blue mark

## 11. Prizes

Prizes will be provided by Elite Octane Inc. as follows:

(Cash Awards awarded to 1<sup>st</sup> place winners only, applicable on minimum 6 Entries per Class. Trophy & Certificate applicable to all)

<input type="checkbox"/> <b>2 Wheelers - 2 Stroke - Super Sport Indian</b>	
<b>Class M</b>	<b>First Prize (INR)</b>
<input type="checkbox"/> Upto 165 cc ( <b>M1</b> )	10,000.00
<input type="checkbox"/> 166 to 375 cc ( <b>M2</b> )	10,000.00

<input type="checkbox"/> <b>2 Wheelers - 4 Stroke - Super Sport Indian</b>	
<b>Class M</b>	<b>First Prize (INR)</b>
<input type="checkbox"/> Upto 165 cc ( <b>M3</b> )	10,000.00
<input type="checkbox"/> 166 cc – 225 cc ( <b>M4</b> )	10,000.00
<input type="checkbox"/> 226 cc – 360 cc ( <b>M5</b> )	10,000.00
<input type="checkbox"/> 361 cc – 550 cc ( <b>M6</b> )	10,000.00
<input type="checkbox"/> Indian Open ( <b>O1</b> )	50,000.00
<input type="checkbox"/> Indian Wheelie ( <b>W1</b> )	10,000.00

<input type="checkbox"/> <b>2 Wheelers - 4 Stroke - Super Sport</b>	
<b>Class M</b>	<b>First Prize (INR)</b>
<input type="checkbox"/> 551 cc – 850 cc (Sport - Inline 3/4) ( <b>M7</b> )	12,000.00
<input type="checkbox"/> 649 cc – 850 cc (Single / Twin) ( <b>M8</b> )	12,000.00
<input type="checkbox"/> 851 cc – 1050 cc ( <b>M9</b> )	12,000.00
<input type="checkbox"/> 1051 cc and above ( <b>M10</b> )	12,000.00
<input type="checkbox"/> Muscle ( <b>P</b> )	12,000.00
<input type="checkbox"/> Foreign Open ( <b>O2</b> )	50,000.00
<input type="checkbox"/> Foreign Wheelie ( <b>W2</b> )	12,000.00

<input type="checkbox"/> <b>4 Wheelers - Pro Stock Petrol</b>	
<b>Class B</b>	<b>First Prize (INR)</b>
<input type="checkbox"/> Upto 1150 cc ( <b>B1</b> )	10,000.00
<input type="checkbox"/> 1151 cc – 1450 cc ( <b>B2</b> )	10,000.00
<input type="checkbox"/> 1451 cc – 1650 cc ( <b>B3</b> )	10,000.00
<input type="checkbox"/> 1651 cc – 2050 cc ( <b>B4</b> )	10,000.00
<input type="checkbox"/> 2051 cc – 2550 cc ( <b>B5</b> )	10,000.00
<input type="checkbox"/> 2551 cc – 3060 cc ( <b>B6</b> )	10,000.00
<input type="checkbox"/> 3061 cc and above ( <b>B7</b> )	10,000.00

<input type="checkbox"/> <b>4 Wheelers - Pro Stock Diesel</b>	
<b>Class K</b>	<b>First Prize (INR)</b>
<input type="checkbox"/> Upto 1150 cc ( <b>K1</b> )	10,000.00
<input type="checkbox"/> 1151 cc – 1450 cc ( <b>K2</b> )	10,000.00
<input type="checkbox"/> 1451 cc – 1650 cc ( <b>K3</b> )	10,000.00
<input type="checkbox"/> 1651 cc – 2050 cc ( <b>K4</b> )	10,000.00
<input type="checkbox"/> 2051 cc – 2550 cc ( <b>K5</b> )	10,000.00
<input type="checkbox"/> 2551 cc – 3060 cc ( <b>K6</b> )	10,000.00
<input type="checkbox"/> 3061 cc and above ( <b>K7</b> )	10,000.00

<input type="checkbox"/> <b>4 Wheelers – Indian Cars with Foreign Engine</b> (minimum 4 to form Class or the class will be merged with the next higher Class). Cannot run in Indian Open, but can take part in Unrestricted Class	
<b>Class F</b>	<b>First Prize (INR)</b>
<input type="checkbox"/> ( <b>F</b> )	12,000.00

<input type="checkbox"/> <b>4 Wheelers – Unrestricted – Indian</b>	
<b>Class G</b>	<b>First Prize (INR)</b>
<input type="checkbox"/> Indian Open ( <b>G1</b> )	12,000.00
<input type="checkbox"/> Indian Open ( <b>G2</b> )	50,000.00

<input type="checkbox"/> <b>4 Wheelers – PRO STOCK – Petrol/Diesel - Foreign</b>	
<b>Class I</b>	<b>First Prize (INR)</b>
<input type="checkbox"/> Upto 3000 cc ( <b>I1</b> )	10,000.00
<input type="checkbox"/> 3001 to 4000 cc ( <b>I2</b> )	10,000.00
<input type="checkbox"/> 4001 cc and above ( <b>I3</b> )	10,000.00

<input type="checkbox"/> <b>4 Wheelers – Unrestricted – Indian, Foreign (All types)</b>	
<b>Class J</b>	<b>First Prize (INR)</b>
<input type="checkbox"/> All types ( <b>J</b> )	50,000.00

## 12. Protest & Appeal

### 12.1 LODGING A PROTEST OR APPEAL

All protests and / or appeals must be lodged in accordance with the stipulations of Articles 13,14 and 15 of the Code.

### 12.2 PROTEST FEES

12.2.1 For Closed, Closed Invitation and Open Events, the protest fees is INR 7,080.00 (Rupees Seven Thousand Eighty Only) (INR 6,000+ INR 1,080 GST)

- 12.2.2 If a protest requires the dismantling and re-assembly of a clearly defined part of the car any additional deposit must be specified in the Supplementary Regulations– or will be specified by the Stewards upon a proposal of the FMSCI Technical Delegate / Chief Scrutineer.
- 12.2.3 If the protest is overruled or it is withdrawn after being brought, no part of the fee shall be returned. (Article 13.10.1 of FIA International Sporting Code)
- 12.2.4 If it is proved that the author of the protest has acted in bad faith, the FMSCI may inflict upon them one of the penalties laid down in the Code. (Article 13.10.3 of sporting code)

### 12.3 APPEALS

Intention to Appeal: INR 56,640/= (Rupees Fifty Six Thousand Six Hundred Forty Only)  
(INR 48,000/= +INR 8,640/= GST)

Within 96 hrs further: INR 56,640/= (Rupees Fifty Six Thousand Six Hundred Forty Only)  
(INR 48,000/= +INR 8,640/=ST)

- Competitors may appeal against decisions, in accordance with the stipulations set out in Articles 15.1 of the Code.
- Competitors have the right to appeal against a sentence or other decisions pronounced on them by the Stewards of the meeting. They must, however under pain of forfeiture of their right to appeal, notify the Stewards of the Meeting in writing within one hour of the publication of the decision, of their intention to appeal along with a fee of INR 56,640/= (Rupees Fifty Six Thousand Six Hundred Forty only).
- The right to bring an appeal to the FMSCI expires 96 hours after the date of the decision of the Stewards of the event on condition that the intention of appealing has been notified in writing to the Stewards of the event within one hour of the decision (see previous paragraph). This appeal may be brought by fax or by any other electronic means of communication with confirmation of receipt. Confirmation by a letter of the same date accompanied by the necessary fee is required. The FMSCI will give its decision within a maximum of 30 days.
- All parties concerned shall be given adequate notice of the hearing of any appeal. They shall be entitled to call witnesses, but their failure to attend the hearing shall not interrupt the course of the proceedings.
- The confirmation of an appeal to the FMSCI must be accompanied by an additional fee of INR 56,640/= (Rupees Fifty Six Thousand Six Hundred Forty only)..
- This fee becomes due from the moment the appellant notifies the Steward of the intention of appealing, and remains payable even if the appellant does not follow up the declared intention to appeal.
- If the appeal is rejected or it is withdrawn after being brought, no part of the fee shall be returned.
- If judged partially founded, the fee may be returned in part, and in its entirety if the appeal is upheld.
- If it is proved that the author of the appeal has acted in bad faith, the FMSCI may inflict upon them one of the penalties laid down in the Code.

## 13. Running of the Event

Surface: Tarmac

Distance: 402 metres, ¼ mile

Braking Distance: 500 meters. Braking area of around 500 meters and run-off of 75 meters for the remaining distance.

Width of the track: 18 metres

Maximum Number of runs per day including practice: 175 (25 additional if allowed by Stewards)

## 14. Safety Requirements

Safety requirements strictly as per FMSCI guidelines of Drag Racing for 2018.

Please refer 2W Technical Regulations: <https://goo.gl/RQsoE9>

Please refer 4W Technical Regulations: <https://goo.gl/d3gQMm>

## Names and photographs of CROs

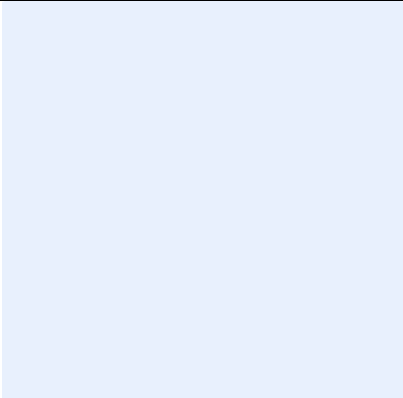
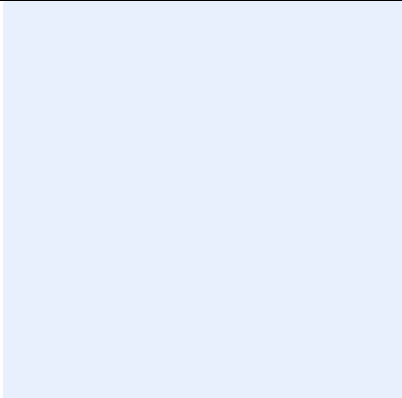
	
	CRO NAME
	MOBILE
	email

Will be present at:

- At the Secretariat.
- At the start of the scrutineering.
- Near the "PIT AREA".

**APPENDIX 1: COMPETITION NUMBERS & ADVERTISING**

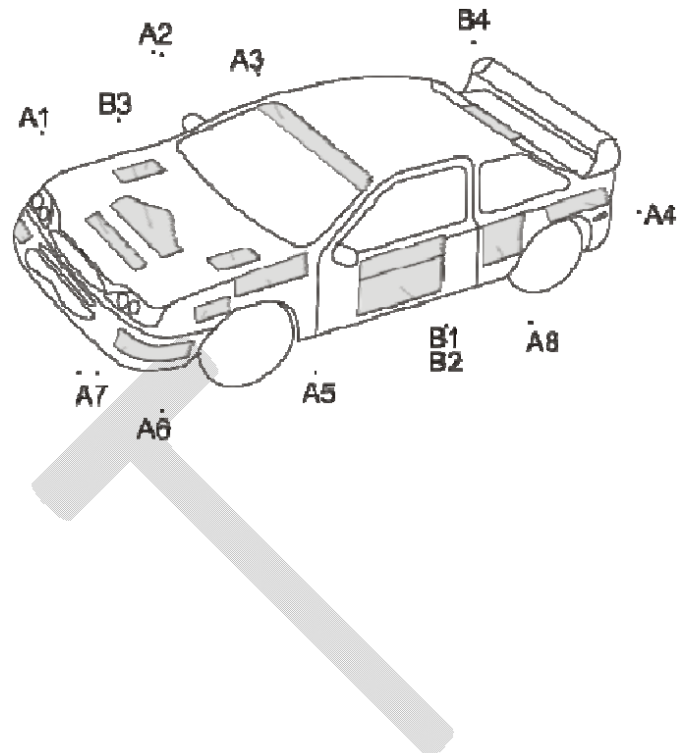

- A1 : TBA
- A2 : Club/Sponsor
- A3 : Sponsor
- A4 : Sponsor
- A5 : TBA
- A6 : TBA
- A7 : TBA
- B1 ~ B3: Competition Number

**DOCUMENTATION / INFORMATION REQUIRED FOR ISSUE OF PERMIT**

- Risk Analysis document duly filled in and signed by the Organizer and COC
- Safety & Medical Document duly filled in & signed both by the CMO & COC.
- Associate Hospital close by, Distance by Road and Hospital confirmation letter for acceptance of any injured participant if required for treatment.
- Track Layout Drawing, Barricading Drawing, Pits Location drawing, Assembly Area Drawing, Scrutiny Area Drawing, COC and Stewards Area drawing.
- List of permissions applied for and acknowledgement of application from the department.
- 3rd party event Insurance copy.
- Preferred date for track inspection by FMSCI delegate.

- Details of Timing Equipment being used.